

Test Report issued under the responsibility of:



TEST REPORT IEC 60884-1 Plugs and socket-outlets for household and similar purposes Part 1: General requirements	
Report Number :	MI18-0029498-01
Date of issue :	25/09/2018
Total number of pages	32 (test report) + 10 (Italian National Differences) + 5 (Annexes)
Name of Testing Laboratory preparing the Report	IMQ S.p.A. Via Quintiliano, 43 – I-20138 Milano
Applicant's name	4BOX SRL
Address	piazzale Segesta 15 – 20148 Milano - Italy
Test specification:	
Standard	IEC 60884-1:2002 (Third Edition) + A1:2006 + A2:2013
Test procedure	CB Scheme
Non-standard test method	N/A
Test Report Form No.	IEC60884_1D
Test Report Form(s) Originator :	IMQ S.p.A.
Master TRF	Dated 2016-04
Copyright © 2015 Worldwide System for Conformity Testing and Certification of Electrotechnical Equipment and Components (IECEE), Geneva, Switzerland. All rights reserved.	
This publication may be reproduced in whole or in part for non-commercial purposes as long as the IECEE is acknowledged as copyright owner and source of the material. IECEE takes no responsibility for and will not assume liability for damages resulting from the reader's interpretation of the reproduced material due to its placement and context.	
If this Test Report Form is used by non-IECEE members, the IECEE/IEC logo and the reference to the CB Scheme procedure shall be removed.	
This report is not valid as a CB Test Report unless signed by an approved CB Testing Laboratory and appended to a CB Test Certificate issued by an NCB in accordance with IECEE 02.	
General disclaimer:	
The test results presented in this report relate only to the object tested. This report shall not be reproduced, except in full, without the written approval of the Issuing CB Testing Laboratory. The authenticity of this Test Report and its contents can be verified by contacting the NCB, responsible for this Test Report.	

Test item description	fixed Socket-outlets	
Trade Mark	 4BOX (logo)	
Manufacturer	4BOX SRL – piazzale Segesta 15 – 20148 Milano - Italy	
Model/Type reference	Bitappo (see also “General product information”)	
Ratings	16 A – 250 V~	
Responsible Testing Laboratory (as applicable), testing procedure and testing location(s):		
<input checked="" type="checkbox"/>	CB Testing Laboratory:	IMQ S.p.A.
Testing location/ address		I – 20138 Milano – Via Quintiliano 43
<input type="checkbox"/>	Associated CB Testing Laboratory:	
Testing location/ address		
Tested by (name, function, signature)		Mascheroni V.
Approved by (name, function, signature) ...:		Primicerio A.
<input type="checkbox"/>	Testing procedure: CTF Stage 1:	
Testing location/ address		
Tested by (name, function, signature)		
Approved by (name, function, signature) ...:		
<input type="checkbox"/>	Testing procedure: CTF Stage 2:	
Testing location/ address		
Tested by (name + signature)		
Witnessed by (name, function, signature) .:		
Approved by (name, function, signature) ...:		
<input type="checkbox"/>	Testing procedure: CTF Stage 3:	
<input type="checkbox"/>	Testing procedure: CTF Stage 4:	
Testing location/ address		
Tested by (name, function, signature)		
Witnessed by (name, function, signature) .:		
Approved by (name, function, signature) ...:		
Supervised by (name, function, signature) :		

List of Attachments (including a total number of pages in each attachment):

Test report IEC 60884-1:2002 (Third Edition) + A1:2006 + A2:2013	: 32 pages
Attachment "ITALIAN NATIONAL DIFFERENCES"	: 10 pages
Annex 1 : Dimensional checking	: 2 pages
Annex 2 "Photographic Documentation"	: 3 pages

Summary of testing:**Tests performed (name of test and test clause):**

This test report refers to complete tests except the following clauses, considered as not applicable: 12.3 – 14 – 15 – 16.2.2 – 19.2 – 19.3 – 23 – 24.14 – 24.15 – 24.16 and 30

Testing location:

IMQ S.p.A.
I – 20138 Milano – Via Quintiliano 43

Summary of compliance with National Differences

List of countries addressed: List of countries addressed: Attachment IT_ND_IEC60884_1D to test report IEC 60884-1:2002 (Third Edition) + A1:2006 + A2:2013 Italian national differences, based on Standards CEI 23-50:2007 +V1:2008 +V2:2011 +V3:2015.

Copy of marking plate (for example):

The artwork below may be only a draft. The use of certification marks on a product must be authorized by the respective NCBs that own these marks.

16 /250 ~

bitappo 4B.N.BT



Test item particulars	: Fixed socket-outlets
Standard Sheet	: P17/11
Rated current (A) / Rated voltage (V)	: 16A / 250V
Degree of protection against access to hazardous parts and against harmful ingress of solid foreign objects	: IP2X / IP4X / IP5X
Degree of protection against harmful ingress of water	: IPX0 / IPX4 / IPX5 / IPX6
Provision for earthing	: without earthing contact / with earthing contact
Method of connecting the cable	: rewirable / non-rewirable
Type of cable	: -
Nominal cross-sectional areas (mm²)	: -
Type of terminals	: screw-type / screwless (rigid) / screwless (rigid and flexible)
Type of connections	: soldered / welded / crimped / other
Socket-outlets:	
Degree of protection against electric shock	: normal protection / increased protection
Existence of shutters	: without shutters / with shutters
Method of application / mounting of the socket-outlet	: surface-type / flush-type / semi-flush-type / panel type / architrave-type / portable type / table-type (single/multiple) / floor recessed type / appliance type
Method of installation	: design A / design B
Intended for circuits where	: a single earthing circuit provides protective earthing / electrical noise immunity is desired for the earthing circuit
Plugs:	
Class of equipment	: 0 / I / II
Possible test case verdicts:	
- test case does not apply to the test object	: N/A
- test object does meet the requirement.....	: P (Pass)
- test object does not meet the requirement	: F (Fail)
Testing	
Date of receipt of test item	: 30/07/2018 (sample sent by applicant) BEM 92053
Date (s) of performance of tests	: from 30/07/2018 up to 25/09/2018

General remarks:

The test results presented in this report relate only to the object tested.
This report shall not be reproduced, except in full, without the written approval of the Issuing testing laboratory.

"(See Enclosure #)" refers to additional information appended to the report.

"(See appended table)" refers to a table appended to the report.

Throughout this report a comma / point is used as the decimal separator.

Unless otherwise stated the uncertainties for the tests and measurements are evaluated in accordance with IMQ Operational Instruction IO-LAB-001 and IO-LAB-004. The uncertainties evaluation has been carried out in accordance with IEC Guide 115 "Application of Uncertainty of measurement's to Conformity Assessment Activity in the Electrotechnical Sector" and IECCE OD-5014. Internal Procedure PG-037 ensures that the requirements for traceability of calibrations, of all test equipment requiring calibration, and calibration intervals are met. The ability of reliability of this product to perform its intended function in a particular application has not been investigated. Unless otherwise specified, warnings, installation instructor and/or user manual provided with the sample have been checked in Italian or English version only.

Manufacturer's Declaration per sub-clause 4.2.5 of IECCE 02:

The application for obtaining a CB Test Certificate includes more than one factory location and a declaration from the Manufacturer stating that the sample(s) submitted for evaluation is (are) representative of the products from each factory has been provided.....:

Yes

Not applicable

When differences exist; they shall be identified in the General product information section.

Name and address of factory (ies) Lumi legend Electrical Co. Ltd.

**N° 18 Lane 239 – Beihai Road, Jiangbei, Ningbo
315032 P.R. CHINA.**

General product information:

Description of fixed sockets compatible with supporting frames of various brands:

Description of the Fixed socket-outlets Series Bitappo		
Type reference	Ratings	Colour
4B.N.BT	16A 250V~	White
4B.L.BT	16A 250V~	Anthracite
4B.V19.BT	16A 250V~	Anthracite
4B.G20.BT	16A 250V~	White
4B.AM.BT	16A 250V~	White
4B.V14.BT	16A 250V~	White
4B.V19B.BT	16A 250V~	White
4B.NT.BT	16A 250V~	Tec

IEC 60884-1			
Clause	Requirement + Test	Result - Remark	Verdict
8	MARKING		
8.1	Accessories marked as follows:		
	- rated current (A)	16 A	P
	- rated voltage (V)	250 V	P
	- symbol for nature of supply	~	P
	- manufacturer's or responsible vendor's name	4b OX	P
	- type reference	4B.N.BT (see general product information)	P
	- degree of protection (first characteristic numeral) if higher than 2.....		N/A
	- degree of protection (second characteristic numeral) if higher than 0.....		N/A
	- degree of protection (first characteristic numeral) higher than 4 for fixed socket outlet in which case the second characteristic numeral shall also be marked		N/A
	- degree of protection (second characteristic numeral) higher than 2 for fixed socket outlet in which case the first characteristic numeral shall also be marked.....		N/A
	Socket-outlets with screwless terminals marked with the following:		
	- the length of insulation to be removed		N/A
	- an indication of the suitability to accept rigid conductors only (if any)		N/A
8.2	Symbols used: as required in the standard		P
	Marking for the nature of supply placed next to the marking for rated current and rated voltage		P
8.3	Marking of fixed socket-outlets placed on the main part:		
	- rated current, rated voltage and nature of supply		P
	- identification mark of the manufacturer or of the responsible vendor		P
	- length of insulation to be removed, if any		N/A
	- indication of the suitability to accept rigid conductors only for screwless terminals for those socket-outlets having this restriction	r	N/A
	- type reference		P
	Cover plates necessary for safety purposes and intended to be sold separately: marked with the manufacturer's or responsible vendor's name and type reference		P
	IP code, if applicable: marked so as to be easily discernible		N/A

IEC 60884-1			
Clause	Requirement + Test	Result - Remark	Verdict
	Fixed socket-outlets classified according to item b) of 7.2.5: identified by a triangle visible after installation unless they have an interface configuration different from that used in normal circuits		N/A
8.4	Plugs and portable socket-outlets: marking specified in 8.1, other than the type reference, easily discernible		N/A
	Plugs and portable socket-outlets for equipment of class II not marked with the symbol for class II construction		N/A
8.5	Neutral terminals: N		N/A
	Earthing terminals: [earth symbol]		P
	Markings not placed on screws or other easily removable parts		P
	Terminals for conductors not forming part of the main function of the socket-outlet:		
	- clearly identified unless their purpose is self-evident, or		P
	- indicated in a wiring diagram fixed to the accessory		P
	Identification of such terminals may be achieved by:		
	- their being marked with graphical symbols according to IEC 60417-2 or colours and/or alphanumeric system, or		N/A
	- their being marked with their physical dimensions or relative location		N/A
8.6	Surface-type mounting boxes forming an integral part of socket-outlets having an IP code higher than IP4X, or higher than IPX2, the IP code marked on the outside of its associated enclosure so as to be easily discernible		N/A
8.7	Indication of which position or with which special provision the declared IP of flush-type and semi-flush-type fixed socket-outlets having IP>X0 is ensured		N/A
8.8	Marking durable and clearly legible with normal or corrected vision, without additional magnification. Test: 15 s with water and 15 s with petroleum spirit		P
9	CHECKING OF DIMENSIONS		
9.1	Accessories and surface-type mounting boxes comply with the appropriate standard sheets and corresponding gauges, if any	* See Attachment and Annex 1	*
	Insertion of plugs into fixed or portable socket-outlets ensured by their compliance with the relevant standard sheets		P

IEC 60884-1			
Clause	Requirement + Test	Result - Remark	Verdict
	Compliance checked by measurement and by means of gauges with manufacturing tolerances as shown in table 2	* See Attachment and Annex 1	*
9.2	It is not possible to engage a plug with:		
	- a socket-outlet having a higher voltage rating or a lower current rating;		P
	- a socket-outlet with a different number of live poles (exception admitted provided that no dangerous situation can arise);		P
	- a socket-outlet with earthing contact, if the existing plug of the present national system is a plug for class 0 equipment;		*
	Engagement of an existing plugs on the present national system for equipment of class 0 or of class I with a socket-outlet exclusively designed to accept plugs for class II equipment		N/A
	Impossibility of insertion checked by applying a gauge, for 1 min, with a force of:		
	- 150 N (rated current \leq 16A);	* See Attachment and Annex 1	*
	- 250 N (rated current $>$ 16A)		N/A
	Accessories with elastomeric or thermoplastic material: test carried out at (35 ± 2) °C		P
9.3	Deviations from standard sheets made only if they provide technical advantage and do not affect the purpose and safety of accessories complying with standard sheet		N/A

10	PROTECTION AGAINST ELECTRIC SHOCK		
10.1	Live parts not accessible, even after removal of parts which can be removed without the use of a tool for:		
	Fixed socket-outlets		P
	Plugs when the plug is in partial or complete engagement with a socket-outlet		P
	Test with test probe B of IEC 61032		P
	Accessories with elastomeric or thermoplastic material: additional test carried out at (35 ± 2) °C with test probe 11 of IEC 61032 (75 N for 1 min)		P
	During the test: accessories not deform and no live parts accessible		P
	Plugs and portable socket-outlets pressed with a force of 150 N for 5 min as shown in figure 8: specimens not show deformation		N/A

IEC 60884-1			
Clause	Requirement + Test	Result - Remark	Verdict
10.2	Accessible parts (with exception of small screws and the like for fixing main parts and covers or cover plates): made of insulating material		P
	Cover or cover plates of fixed socket-outlets and accessible parts of portable socket-outlets: made of metal if the requirements of 10.2.1 or 10.2.2 are fulfilled		N/A
10.2.1	Accessible metal parts or accessible metal parts protected by supplementary insulation made by insulating linings or insulating barriers		N/A
	Insulating linings or insulating barriers cannot be removed without being permanently damaged		N/A
	Insulating linings or insulating barriers cannot be replaced in an incorrect position and, if they are omitted, accessories are rendered inoperable or manifestly incomplete		N/A
	There is no risk of accidental contact between live parts and metal covers or cover plates		N/A
10.2.2	Accessible metal parts are reliably connected, through a low-resistance connection, to the earth during fixing		N/A
10.3	Contact between a pin of a plug and a live socket-contact of a socket-outlet not possible while any other pin is accessible		P
	Compliance checked by manual test and by means of gauges with tolerances as specified in table 2		P
	Accessories with elastomeric or thermoplastic material: test carried out at $(35 \pm 2) ^\circ\text{C}$		P
	Socket-outlets with enclosure or bodies of rubber or polyvinyl chloride: test carried out with a force of 75 N for 1 min		P
	Fixed socket-outlets provided with metal covers or cover plates: clearance of at least 2 mm required between a pin and a socket-contact when another pin(s) is(are) in contact with the metal covers or cover plates (mm)		N/A
10.4	External parts of plugs made of insulating material		N/A
	Overall dimensions of rings around pins not exceed 8 mm concentric with respect to the pin		N/A
10.5	Shuttered socket-outlets: live parts not accessible, without a plug in engagement, with the gauges shown in figure 9 and 10		P
	Live contacts automatically screened when the plug is withdrawn		P

IEC 60884-1			
Clause	Requirement + Test	Result - Remark	Verdict
	Shutters so designed that a plug is inserted with the same movement in a socket outlet with shutters as in a socket-outlet without shutters		P
	Means cannot easily be operated by anything other than a plug and not depend upon parts which are liable to be lost		P
	Gauge of figure 9, applied to the entry holes corresponding to live contacts with a force of 20 N, for approximately 5 s, successively in three directions, does not touch live parts		P
	Steel gauge of figure 10, applied to the entry holes corresponding to live contacts with a force of 1 N for approximately 5 s, in three directions, does not touch live parts		P
	Accessories with elastomeric or thermoplastic material: test carried out at $(35 \pm 2) ^\circ\text{C}$		P
10.6	Earthing contacts of a socket-outlet designed that they cannot be deformed by the insertion of a plug		P
	Test plug inserted into the socket-outlet with a force of 150 N for 1 min		
10.6	Earthing contacts of a socket-outlet designed that they cannot be deformed by the insertion of a plug		P
	After this test: socket-outlet still comply with the requirements of clause 9		P
10.7	Socket-outlet with or without lid with increased protection: live parts not accessible		P
	Test wire of 1 mm diameter (figure 10) applied with a force of 1 N on all accessible surfaces does not touch live parts		P
	Accessories with elastomeric or thermoplastic material: test carried out at $(35 \pm 2) ^\circ\text{C}$		P
	Socket-outlet tested without a plug inserted with the lid, if any, open		P
11	PROVISION FOR EARTHING		
11.1	Earth connection made before the current-carrying contacts of the plug become live		P
	Current-carrying pins are separated before the earth connection is broken		P
11.2	Earthing terminals of rewirable accessories comply with clause 12		P
	Earthing terminals of the same size as the corresponding terminals for the supply conductors		P
	Earthing terminals of rewirable accessories: internal		P
	Earthing terminals of fixed socket-outlets: fixed to the base or to a part reliably fixed to the base		P

IEC 60884-1			
Clause	Requirement + Test	Result - Remark	Verdict
	Earthing contacts of fixed socket-outlets:		
	- fixed to the base, or		P
	- fixed to the cover (reliably connected to the earthing terminals; contact pieces silver plated or with adequate protection)		N/A
	Parts of earthing circuit in one piece or reliably connected by riveting, welding, or the like		P
11.3	Accessible metal parts of fixed socket-outlets: permanently and reliably connected to the earthing terminal		N/A
11.4	Socket-outlets, having an IP>X0, with enclosure of insulating material and more than one cable inlet, provided with:		
	- an internal fixed earthing terminal, or		N/A
	- adequate space for a floating terminal (test connection using the type of terminal specified by the manufacturer), unless		N/A
	- earthing terminal of socket-outlet itself allows the connection of an incoming and an outgoing earthing conductor		N/A
11.5	Connection between earthing terminal and accessible metal parts: of low resistance		N/A
	Test current equal to 1,5 times the rated current or 25 A (A)		—
	Resistance not exceed 0,05 Ω (Ω)		N/A
11.6	Fixed socket-outlets according to item b) of 7.2.5: earthing socket contact and its terminal electrically separated from any metal mounting means or other exposed conductive parts which may be connected to the protective earthing circuit of the installation		N/A
12	TERMINALS AND TERMINATIONS		
	All the test on terminals, with the exception of the tests of 12.3.11 and 12.3.12, made after the test of clause 16		P
12.1	General		
12.1.1	Rewirable fixed socket-outlets provided with screw-type terminals or with screwless terminals	Screw terminal	P
	Rewirable plugs and portable socket-outlets provided with terminals with screw clamping		N/A
	Pre-soldered flexible conductors used: pre-soldered area outside the clamp area of screw-type terminals		N/A
	Clamping means of terminals: not serve to fix any other components		N/A

IEC 60884-1			
Clause	Requirement + Test	Result - Remark	Verdict
12.1.2	Non-rewirable accessories provided with soldered, welded, crimped or equally effective permanent connections (termination)		N/A
	Screwed or Snap-On connections not used		N/A
	Connections made by crimping a pre-soldered flexible conductor not permitted		N/A
12.2	Terminals with screw clamping for external copper conductors		
12.2.1	Accessories provided with terminals which allows the proper connection of copper conductors as shows in table 3		
	Rated current (A); Type of accessories	16 A	—
	Type of conductor (rigid / flexible)	rigid	—
	Smallest / largest cross-sectional area (mm ²)	1,5 - 2,5 mm ²	—
	Diameter of the largest conductor (mm)	2,13 mm	—
	Figure of terminal	3	—
	Minimum diameter D (minimum dimensions) of conductor space: required (mm); measured (mm) :	required (mm): 2,0 mm measured (mm): 3,0 mm	P
12.2.2	Terminals allow the conductor to be connected without special preparation		P
12.2.3	Terminals have adequate mechanical strength		P
	Screws and nut for clamping the conductors have metric ISO thread or a comparable thread		P
	Screws not of soft metal such as zinc or aluminium		P
12.2.4	Terminals resistant to corrosion		P
12.2.5	Terminals clamp the conductor(s) without undue damage	See appended table 12.2.5	P
	During the test: conductor not slip out, no break near clamping unit and no damage		P
12.2.6	Terminals clamp the conductor reliably between metal surfaces	See appended table 12.2.6	P
	During the test: conductor not move noticeably		P
12.2.7	Terminals designed or placed that the conductor cannot slip out while the clamping screws or nuts are tightened	See appended table 12.2.7	P
	After the test: no wire of the conductor escaped from the clamping unit		P
12.2.8	Terminals not work loose from their fixing to accessories		P
	Torque test (screws and nuts tightened and loosened 5 times):		
	- rated current (A)	16 A	—

IEC 60884-1			
Clause	Requirement + Test	Result - Remark	Verdict
	- copper conductor of the largest cross-sectional area (mm ²) (table 3)	2,5 mm ²	—
	- type of conductor (solid or stranded)	solid	—
	- torque (Nm) (table 6 or appropriate figures 2, 3 or 4)	0,8 Nm; (figure 3)	—
	During the test: terminals not work loose and show no damage		P
12.2.9	Clamping screws or nuts of earthing terminals: adequately locked against accidental loosening, not possible to loosen them without the aid of a tool		P
12.2.10	Earthing terminals: no risk of corrosion		P
	Body of brass or other metal no less resistant to corrosion		P
	The body is a part of a frame or enclosure of aluminium alloy: precautions are taken to avoid the risk of corrosion		N/A
12.2.11	Pillar terminals: distance <i>g</i> no less than the value specified in figure 2: required (mm); measured (mm)		N/A
	Mantle terminals: distance <i>g</i> no less than the value specified in figure 5: required (mm); measured (mm)		N/A
12.3	Screwless terminals for external copper conductors		N/A

13	CONSTRUCTION OF FIXED SOCKET-OUTLETS		
13.1	Socket-contact assembly have sufficient resilience to ensure adequate contact pressure on plug pins		P
	Part of socket-contact assembly ensure metallic opposing contacts at least on two sides of each pins		P
13.2	Socket-contact and pin(s) of socket-outlet which are made of copper or copper alloy, as specified in 26.5, are considered as complying with this requirement		P
	The pin(s) of socket-outlets so constructed in such a way that the mechanical strength of the pin(s) does not depend on the plastic material		N/A
	Compliance is checked by inspection and in case of doubt by the tests of 14.2 and Clause 21 on a new set of specimens without plastic		P
13.3	Insulating linings, barriers and the like: adequate mechanical strength		P
13.4	Socket-outlets constructed as to permit		
	- easy introduction into the terminal and reliable connection of the conductors in the terminals, except for lead wires of pilot lights		P

IEC 60884-1			
Clause	Requirement + Test	Result - Remark	Verdict
	- easy fixing of the main part to a wall or in a mounting box		P
	- correct positioning of the conductors		P
	- adequate space between the underside of the main part and the surface on which the main part is mounted;		P
	- adequate space between the sides of the main part and the enclosure (cover or box);		P
	Socket-outlets having screwless terminals, constructed that the connecting and/or disconnecting means of the screwless terminals cannot be activated by the conductors during and after installation		N/A
	Compliance is checked by inspection and in case of doubt by the following test		N/A
	The test is carried out with a solid copper conductor having the smallest cross-sectional area, as specified in 12.3.2. (mm ²).....:		N/A
	If it is not possible to exert a force onto the connecting/disconnecting device, the product is deemed to comply with the requirements without further tests.		N/A
	During the application of the pull, the conductor do not come out of the screwless terminal		N/A
	In addition socket-outlets classified as design A: permit easy positioning and removal of the cover or cover plate, without displacing the conductors or activating the connecting and/or disconnecting means of screwless terminals.		P
	Compliance is checked by inspection and by an installation test with conductors of the largest nominal cross-sectional area specified in Table 3 (mm ²).....:	2x2,5 mm ²	P
13.5	Socket-outlets designed that full engagement of associated plugs is not prevented by any projection from their engagement face		P
	Gap between the engagement face of the socket-outlet and the plug: not exceed 1 mm		P
13.6	Covers provided with bushings for the entry holes for the pins: not possible to remove them from the outside or for them to become detached inadvertently from the inside when the cover is removed		N/A
13.7	Covers, cover-plates or parts of them intended to ensure protection against electric shock:		
	- held in place at two or more points by effective fixings		N/A

IEC 60884-1			
Clause	Requirement + Test	Result - Remark	Verdict
	- fixed by means of a single fixing, for example, by a screw, provided that they are located by another means (for example, by a shoulder)		N/A
	Fixings of covers or cover-plates of socket-outlets of design A serve to fix the main parts: there are means to maintain the base in position, even after removal of the covers or cover-plates		N/A
13.7.1	Covers or cover-plates whose fixings are of the screw-type:		
	Compliance checked by inspection only		
13.7.2	Covers or cover-plates whose fixing is not dependent on screws and whose removal is obtained by applying a force in a direction approximately perpendicular to the mounting/supporting surface:		
	Compliance checked, when their removal may give access, with the standard test finger:		
	to live parts: by the test of 24.14 (verification of the non-removal and the removal)		N/A
	to non-earthed metal parts separated from live parts in such a way that creepage distances and clearances have the values shown in table 23: by the test of 24.15 (verification of the non-removal and the removal)		N/A
	only to parts of insulating material, or earthed metal parts, or metal parts separated from live parts in such a way that creepage distances and clearances have twice the values shown in table 23, or live parts of SEL V circuits not greater than 25 V a.c.: by the test of 24.16 (verification of the non-removal and the removal)		N/A
13.7.3	Covers or cover-plates the fixing of which is not dependent on screws and whose removal is obtained by using a tool, in accordance with the manufacturer's instructions given in an instruction sheet or in other documentation:		
	Compliance checked, when their removal may give access, with the standard test finger:		
	to live parts: by the test of 24.14 (verification of the non-removal only)		N/A
	to non-earthed metal parts separated from live parts in such a way that creepage distances and clearances have the values shown in table 23: by the test of 24.15 (verification of the non-removal only)		N/A
	only to parts of insulating material, or earthed metal parts, or metal parts separated from live parts in such a way that creepage distances and clearances have twice the values shown in table 23, or live parts of SEL V circuits not greater than 25 V a.c.: by the test of 24.16 (verification of the non-removal only)		N/A

IEC 60884-1			
Clause	Requirement + Test	Result - Remark	Verdict
13.8	Cover-plate intended for a socket-outlet with earthing contact: not interchangeable with a cover-plate intended for a socket-outlet without earthing contact		N/A
13.9	Surface-type socket-outlets: no free openings in their enclosures		N/A
13.10	Screws or other means for mounting the socket-outlet on a surface in a box or enclosure: easily accessible from the front		N/A
	Fixing means not serve any other fixing purpose		N/A
13.11	Multiple socket-outlets with a common base: provided with fixed links for the interconnection of the contacts in parallel		N/A
	Fixing of the links independent from the connection of the supply wires		N/A
13.12	Multiple socket-outlets, comprising separate bases: correct position of each base ensured		N/A
	Fixing of each base independent of the fixing of the combination to the mounting surface		N/A
13.13	Mounting plate of surface-type socket-outlets: adequate mechanical strength		N/A
13.14	Socket-outlets withstand the lateral strain imposed by equipment likely to be introduced into them		P
	Socket-outlets 16A 250V: test made 4 times with the socket-outlet turned through 90°, 5 N for 1 min (device shown in fig. 13)		P
	During the test: device not become disengaged from the socket-outlet		P
	After the test:		
	- no damage		P
	- socket-outlets comply with clause 22		P
13.15	Socket-outlets are not an integral part of lampholders		P
13.16	Surface-type socket-outlets having IP>20 are according to their IP classification when fitted with conduits or with sheathed cables and without a plug in engagement		N/A
	Surface-type socket-outlets having IPX4 and IPX6 have provision for opening a drain hole		N/A
	Socket-outlets with a drain hole: drain hole is not less than 5 mm in diameter, or 20 mm ² in area with a width and a length of not less than 3 mm		N/A
	Drain hole: effective		N/A

IEC 60884-1			
Clause	Requirement + Test	Result - Remark	Verdict
	Lid springs (if any): of corrosion-resistant material (bronze or stainless steel)		N/A
13.17	Earthing pins: adequate mechanical strength		N/A
	Not solid pins: compliance checked by inspection and by the test of 14.2 made after the tests of clause 21		N/A
13.18	Earthing contacts, phase contacts and neutral contacts :		
	- locked against rotation;		P
	- when the product is ready for the wiring do not possible to be removed without the use of a tool		P
13.19	Metal strips of the earthing circuit: no burrs which might damage the insulation of the supply conductors		N/A
13.20	Socket-outlets to be installed in a box: designed that the conductor ends can be prepared after the box is mounted in position, but before the socket-outlet is fitted in the box		P
13.21	Inlet openings: allow the introduction of the conduit or the sheath of the cable		N/A
	Surface-type socket-outlets:		
	the conduit or sheath of the cable can enter at least 1 mm into the enclosure		N/A
	inlet opening for conduit entries, or at least two of them if there are more than one, capable of accepting conduit sizes of 16, 20, 25 or 32 according to IEC 60423 or a combination of at least two of any of these sizes		N/A
	inlet opening for cable entries capable of accepting cables having the dimensions specified in table 14 or be as specified by the manufacturer: rated current (A); Limits of external dimensions of cable min/max (mm)		N/A
13.22	Membranes (grommets) in inlet openings: reliably fixed and not displaced by the mechanical and thermal stresses occurring in normal use		
	Test on membranes subjected to the ageing treatment specified in 16.1 and assembled in the accessories		
	Accessories placed at (40 ± 2) °C for 2 h. Force of 30 N applied for 5 s by test probe 11 of IEC 61032. During the test: no deformation		N/A
	Membranes likely to be subjected to an axial pull: axial pull of 30 N applied for 5 s. During the test: membranes not become detached		N/A
	After the test: no harmful deformation, cracks or similar damage		N/A

IEC 60884-1			
Clause	Requirement + Test	Result - Remark	Verdict
	Test repeated with membranes not subjected to any treatment		N/A
13.23	Membranes in inlet openings: introduction of the cables into the accessory permitted when the ambient temperature is low		N/A
	Test on membranes not subjected to the ageing treatment specified in 16.1 and assembled in the accessories		
	Accessories kept at (-15 ± 2) °C for 2 h: possibility to introduce cables of the largest diameter through membranes		N/A
	After the test: no harmful deformation, cracks or similar damage		N/A
14	CONSTRUCTION OF PLUGS AND PORTABLE SOCKET-OUTLETS		N/A
15	INTERLOCKED SOCKET-OUTLETS		N/A
16	RESISTANCE TO AGEING, PROTECTION PROVIDED BY ENCLOSURES, AND RESISTANCE TO HUMIDITY		
16.1	Resistance to ageing		
	Accessories are resistant to ageing		P
	For accessories having a lid, the lid is closed during the test		N/A
	Portable socket-outlets: the plug of the same system having the same rated current as the socket-outlet inserted into the socket-outlet during the test		N/A
	Accessories subjected to a test in a heating cabinet at (70 ± 2) °C for seven days (168 h)		P
	After the tests, the specimens show:		
	- no crack visible with normal or corrected vision without additional magnification		P
	- no sticky or greasy material		P
	- no trace of cloth (forefinger pressed with 5 N)		P
	- no damage		P
	Portable socket-outlets: contact pressure of the contact assembly checked as specified in subclause 22.2 with the single-pin gauge		N/A
16.2	Protection provided by enclosures		
	Enclosures provide a degree of protection in accordance with the IP designation of the accessory		N/A

IEC 60884-1			
Clause	Requirement + Test	Result - Remark	Verdict
16.2.1	Protection against access to hazardous parts and against harmful effects due to ingress of solid foreign objects		
	Accessories and their enclosures provide a degree of protection against access to hazardous parts and against harmful effects due to ingress of solid foreign objects		P
	Fixed socket-outlets: mounted as in normal use on a vertical surface		P
	Flush-type and semi-flush type socket-outlets: mounted in an appropriate box according to the manufacturer's instructions		P
	Accessories with screwed glands or membranes fitted with flexible cables within the range specified in table 3:		
	- largest cross-sectional area (mm ²); type of cable (table 17)		—
	- smallest cross-sectional area (mm ²); type of cable (table 17)		—
	Glands tightened with a torque equal to 2/3 of the torque applied during the test of 24.6 (Nm)		—
	Screws of the enclosure tightened with a torque equal to 2/3 of the torque given in table 6 (Nm) ...		—
16.2.1.1	Protection against access to hazardous parts		
	Appropriate test performed as specified in IEC 60529 (see also clause 10)	IP20	P
16.2.1.2	Protection against harmful effects due to ingress of solid foreign objects		
	Appropriate test performed as specified in IEC 60529	IP20	P
	Test on accessories with IP5X (considered to be of category 2): dust not penetrated in a quantity to interfere with satisfactory operation or to impair safety		N/A
	Test on accessories with IP6X (considered to be of category 1): dust do not penetrate		N/A
16.2.2	Protection against harmful effects due to ingress of water		N/A
16.3	Resistance to humidity		
	Accessories proof against humidity which may occur in normal use		P
	Compliance checked by a humidity treatment carried out in a humidity cabinet containing air with relative humidity maintained between 91 % and 95 %		P
	Specimens kept in the cabinet for:		
	- two days (48 h) for accessories having IPX0		P

IEC 60884-1			
Clause	Requirement + Test	Result - Remark	Verdict
	- seven days (168 h) for accessories having IP>X0		N/A
	After this treatment the specimens show no damage		P
17	INSULATION RESISTANCE AND ELECTRIC STRENGTH		
17.1	Insulation resistance measured 1 min after application of 500 V d.c.	See appended table 17.1	P
17.2	Electric strength: a.c. test voltage applied for 1 min	See appended table 17.2	P
18	OPERATION OF EARTHING CONTACTS		
	Earthing contacts provide adequate contact pressure and not deteriorate in normal use		P
	Compliance checked by the tests of clauses 19 and 21		P
19	TEMPERATURE RISE		
	Accessories constructed that they comply with the following temperature rise test		
	Non-rewirable accessories are tested as delivered		N/A
	In the case of multiple socket-outlets, the test is carried out on one socket-outlet of each type and current rating with the test current as specified in Table 20 passed through that one socket-outlet	See appended tables	N/A
	The temperature rise of the terminals, terminations and clamping units according to Figure 44 determined by means of thermocouples do not exceed 45 K	See appended tables	N/A
19.1	Socket-outlets and plugs are tested as follows:		
	Socket-outlets tested using a test plug with brass pins having the minimum specified dimensions	See appended table 19.1	P
	For this test the temperature rise is measured on the terminals and terminations.		P
	Plugs tested with clamping units having dimensions specified in Figure 44 fitted on each live pin and earthing pin, if any	See appended table 19.1	N/A
	Plugs having lateral earthing contacts and resilient earthing contacts tested using a fixed socket-outlet complying with the standard and having as near to-average characteristics as can be selected, but with minimum size of the earthing pin, if any	See appended table 19.1	N/A
19.2	Fixed socket-outlets of a socket-outlet and fused plug system are tested as follows:		
19.3	Portable socket-outlets and rewirable plugs with incorporated components are tested by the following two tests:		

IEC 60884-1			
Clause	Requirement + Test	Result - Remark	Verdict
20	BREAKING CAPACITY		
	Accessories have adequate breaking capacity		P
	Compliance checked by testing:		
	- socket-outlets;	See appended table 20	P
	- plugs with pins which are not solid	See appended table 20	N/A
	Multiple socket-outlets: test carried out on one socket-outlet of each type and current rating		N/A
	During the test: no sustained arcing occur		P
	After the test:		
	- specimens show no damage impairing their further use;		P
	- entry holes for the pins not show any damage which may impair the safety		P
21	NORMAL OPERATION		
	Accessories withstand without excessive wear or other harmful effect, the mechanical, electrical and thermal stresses occurring in normal use		P
	Compliance checked by testing:		
	- socket-outlets;	See appended table 21	P
	- plugs with resilient earthing socket-contacts;	See appended table 21	N/A
	- plugs with pins which are not solid	See appended table 21	N/A
	Test performed according to the procedure specified in Figure 43; point of Figure 43 at which the test program has begun (1, 2, 3)		—
	Test current passed:		
	- during each insertion and withdrawal of the plug ($I_n \leq 16A$)		P
	- during alternate insertion and withdrawal, the other insertion and withdrawal being made without current flowing ($I_n > 16A$)		N/A
	Multiple socket-outlets: test carried out on one socket-outlet of each type and current rating		N/A
	During the test: no sustained arcing occur		P
	After the test the specimens do not show:		
	- wear impairing their further use;		P
	- deterioration of enclosures, insulating lining or barriers;		P
	- damage to the entry holes for the pins, that might impair proper working;		P

IEC 60884-1			
Clause	Requirement + Test	Result - Remark	Verdict
	- loosening of electrical or mechanical connections;		P
	- seepage of sealing compound		N/A
	Shuttered socket-outlets: gauges of figure 9 and 10 applied to the entry holes corresponding to live contacts do not touch live parts when they remain under the relevant forces	See appended table 21	P
	Temperature-rise test (requirements of clause 19)	See appended table 21	P
	Electric strength (sub-clause 17.2)	See appended table 21	P
	Pins which are not solid: test according to 14.2		N/A
22	FORCE NECESSARY TO WITHDRAW THE PLUG		
	Construction of accessory does allow the easy insertion and withdrawal of the plug, and prevent the plug from working out of the socket-outlet in normal use		P
22.1	Verification of the maximum withdrawal force	See appended table 22	P
22.2	Verification of the minimum withdrawal force	See appended table 22	P
23	FLEXIBLE CABLES AND THEIR CONNECTIONS		N/A
24	MECHANICAL STRENGTH		
	Accessories, surface mounting boxes, screwed glands and shrouds have adequate mechanical strength		P
24.1	Fixed socket-outlets, portable multiple socket-outlets and surface-type mounting boxes: hammer test described in IEC 60068-2-75 (test EHA), equivalent mass of 250 g	See appended table 24.1	P
	After the test: no damage, live parts no become accessible		P
24.2	Portable single socket-outlets and plugs: subjected to test Ec: Rough handling shocks, primarily for equipment-type specimens, procedure 2 of IEC 60068-2-31 (tumbling barrel); number of falls.....:		N/A
	After the test:		
	- no part become detached or loosened;		N/A
	- pins no become so deformed that the plug cannot be introduced into a socket-outlet and also fails to comply with the requirements of 9.1 and 10.3;		N/A
	- pins no turn when a torque of 0,4 Nm is applied for 1 min in each direction		N/A

IEC 60884-1			
Clause	Requirement + Test	Result - Remark	Verdict
	The shutters of socket-outlets tested again according to Clause 21, from paragraph 19 up to paragraph 24 (only the tests of shutters)		N/A
24.3	Main parts of surface-type socket-outlets: first fixed to a cylinder of rigid steel sheet and then fixed to a flat steel sheet		
	During and after the tests: no damage		N/A
24.4	Portable single socket-outlets, multiple socket-outlets and plugs (elastomeric or thermoplastic material): impact test, weight (1000 ± 2) g, height 100 mm (apparatus shown in fig. 27)		
	Specimens placed in a freezer at (-15 °C ± 2) °C for at least 16 h. After the test: no damage		N/A
24.5	Portable single socket-outlets and plugs (elastomeric or thermoplastic material): compression test, 300 N for 1 min, position a) and b) (apparatus shown in fig. 8)		
	After the test: no damage		N/A
24.6	Screwed glands of accessories having IP>20: torque test (1 min)		
	- diameter of test rod (mm)		—
	- type of material (metal / moulded)		—
	- torque (Nm)		—
	After the test: no damage of glands and enclosures of the specimens		N/A
24.7	Plug pins provided with insulating sleeves: 20000 movements, 4 N (apparatus shown in fig. 28)		
	After the test: no damage of pins, insulating sleeve not have punctured or rucked up		N/A
24.8	Shuttered socket-outlets: mechanical test carried out on specimens submitted to the normal operation test according to clause 21		
	Force (40 N / 75 N) applied for 1 min against the shutter of an entry hole by means of one pin (N) :	75 N	—
	Pin did not come in contact with live parts		P
	After the test: no damage		P
24.9	Mechanical test for multiple portable socket-outlet: 8 falls on concrete floor with the specimens arranged as shown in figure 29		
	Rewirable multiple socket-outlets: flexible cable of the smallest cross-sectional area specified in table 3		—
	After the test: no damage, no part have become detached or loosened		N/A
	Accessories having IP>X0 submitted again to the tests as specified in 16.2		N/A
	The shutters of multiple socket-outlets tested again according to Clause 21, from paragraph 19 up to paragraph 24 (only the tests of shutters)		N/A

IEC 60884-1			
Clause	Requirement + Test	Result - Remark	Verdict
24.10	Plugs: pull test to verify the fixation of pins in the body of the plug (new specimens)		
	Maximum withdrawal force (table 16) applied for 1 min on each pin in turn, after the specimen has been placed at $(70 \pm 2) ^\circ\text{C}$ for 1 h (N)		—
	After the test: displacement of pins in the body of the plug ≤ 1 mm (mm)		N/A
24.11	Barriers of portable socket-outlets having means for suspension on a mounting surface:		
	Force applied for 10 s against the barrier by means of a cylindrical steel rod (1,5 times the maximum plug withdrawal force in 22.1, table 16) (N)		—
	Rod did not pierce the barrier		N/A
24.12	Portable socket-outlets having means for suspension on a mounting surface (pull test):		
	Pull applied to the supply flexible cable for 10 s (force prescribed in 23.2 for checking the flexible cable anchorage) (N)		—
	During the test: no break of the means for suspension on a mounting surface		N/A
24.13	Portable socket-outlets having means for suspension on a mounting surface (pull test):		
	Pull applied to the engagement face of the socket-outlet for 10 s (maximum withdrawal force specified, for the corresponding plug, in table 16) (N)		—
	During the test: no break of the means for suspension on a mounting surface		N/A
24.14	Forces necessary to retain or remove covers, cover-plates or parts of them (accessibility with the test finger to live parts)		N/A
24.15	Force necessary for covers or cover-plates to come off or not to come off (accessibility with the test finger to non-earthed metal parts separated from live parts by creepage distances and clearances according to table 23)		N/A
24.16	Force necessary for covers or cover-plates to come off or not to come off (accessibility to insulating parts, earthed metal parts, live parts of SELV ≤ 25 V a.c. or metal parts separated from live parts by creepage distances twice those according to table 23)		N/A
24.17	Test with gauge of figure 7 applied according to figure 9 for verification of the outline of covers or cover-plates: distances between face C of gauge and outline of side under test, not decrease	complying / not complying	—
24.18	Test with gauge according to figure 5 applied as shown in figure 11 (1 N): gauge not enter more than 1mm	complying / not complying	—
24.19	Shroud of portable socket-outlets: compression test (20 ± 2) N at $(25 \pm 5) ^\circ\text{C}$ by means of the apparatus shown in figure 38		

IEC 60884-1			
Clause	Requirement + Test	Result - Remark	Verdict

	After 1 min and while the shrouds are still under pressure the dimensions did comply with the appropriate standard sheet		N/A
	Test repeated with the specimen rotated 90 °		N/A

25	RESISTANCE TO HEAT		
25.1	Specimens kept for 1 h in a heating cabinet at (100 ± 2) °C for 1 h		
	During the test: no change impairing their further use and sealing compound, if any, not flow		P
	After the test:		
	- no access to live parts with probe B of IEC 61032 applied with a force not exceeding 5 N		P
	- markings still legible		P
25.2	Parts of insulating material necessary to retain current-carrying parts and parts of the earthing circuit in position, as well as parts of the front surface zone, 2 mm wide, surrounding the phase and neutral pin entry holes: ball-pressure test at (125 ± 2) °C for 1 h	See appended table 25.2	P
25.3	Parts of insulating material not necessary to retain current-carrying parts and parts of the earthing circuit in position, even though in contact with them: ball-pressure test (1 h)	See appended table 25.3	N/A
25.4	Portable accessories: compression test (20 N) at (80 ± 2) °C for 1 h by means of the apparatus shown in figure 38		
	After the test: no damage		N/A

26	SCREWS, CURRENT-CARRYING PARTS AND CONNECTIONS		
26.1	Connections withstand mechanical stresses		P
	Thread-forming or thread-cutting screws used only if supplied together with the piece in which they are intended to be inserted		N/A
	Thread-cutting screws intended to be used during installation: captive		N/A
	Screws or nuts which transmit contact pressure made of metal and in engagement with a metal thread		P
	Threaded part torque test	See appended table 26.1	P
26.2	Screws in engagement with a thread of insulating material: correct introduction into the screw hole or nut ensured		P

IEC 60884-1			
Clause	Requirement + Test	Result - Remark	Verdict
26.3	Contact pressure: not transmitted through insulating material other than ceramic, pure mica or other material no less suitable unless there is sufficient resiliency in metallic parts		P
	Connections made by insulation piercing of tinsel cord reliable		P
26.4	Screws and rivets locked against loosening and/or turning		P
26.5	Current-carrying parts (including earthing terminals) have mechanical strength, electrical conductivity and resistance to corrosion adequate:		
	- copper;		
	- alloy with at least 58 % copper for parts made from cold-rolled sheet or with at least 50 % copper for other parts;		P
	- stainless steel with at least 13 % chromium and not more than 0,09 % carbon		N/A
	- steel with electroplated coating of zinc (ISO 2081): service condition ISO no. (1/2/3); IP (X0/X4/X5); thickness (µm)		N/A
	- steel with electroplated coating of nickel and chromium (ISO 1456): service condition ISO no. (2/3/4); IP (X0/X4/X5); thickness (µm)		N/A
	- steel with electroplated coating of tin (ISO 2093): service condition ISO no. (2/3/4); IP (X0/X4/X5); thickness (µm)		N/A
	Current-carrying parts subjected to mechanical wear: not of steel with electroplated coating		P
	Metals having a great difference of electrochemical potential: not used in contact with each other		P
26.6	Contacts subjected to a sliding action are of metal resistant to corrosion		P
26.7	Thread-forming screws and thread-cutting screws are not used for the connection of current-carrying parts		N/A
	Thread-forming screws and thread-cutting screws used to provide earthing connection: it is not necessary to disturb the connection and at least two screws are used for each connection		N/A
27	CREEPAGE DISTANCES, CLEARANCES AND DISTANCES THROUGH SEALING COMPOUND		
27.1	Creepage distances, clearances and distances through sealing compound are not less than the values shown in table 23	See appended table 27.1	P

IEC 60884-1			
Clause	Requirement + Test	Result - Remark	Verdict
27.2	Insulating sealing compound does not protrude above the edge of the cavity in which it is contained		N/A
27.3	Surface-type socket-outlets do not have bare current-carrying strips at the back		N/A
28	RESISTANCE OF INSULATING MATERIAL TO ABNORMAL HEAT, TO FIRE AND TO TRACKING		
28.1	Resistance to abnormal heat and to fire		
28.1.1	Glow-wire test according to IEC 60695-2-10 and IEC 60695-2-11	See appended table 28.1.1	P
28.1.2	Plugs with pins provided with insulating sleeves:		
	Test temperature maintained for 3 h by means of the apparatus shown in figure 40 at $(120 \pm 5) ^\circ\text{C}$ / $(180 \pm 5) ^\circ\text{C}$		—
	Impact test according to sub-clause 30.4 (mass 100 g, height 100 mm, 4 impacts): no cracks of the insulating sleeves		N/A
28.2	Resistance to tracking		
	Parts of insulating material retaining live parts in position of accessories having IP>X0: of material resistant to tracking		N/A
	Tracking test at 175 V with solution A of IEC 60112	See appended table 28.2	N/A
29	RESISTANCE TO RUSTING		
	Ferrous parts protected against rusting		N/A
	Test made after having removed all grease using a suitable degreasing agent: 10 min 10 % solution of ammonium chloride, 10 min in a box with air saturated with moisture and 10 min at $(100 \pm 5) ^\circ\text{C}$:		
	No signs of rust		N/A
30	ADDITIONAL TESTS ON PINS PROVIDED WITH INSULATING SLEEVES		N/A

IEC 60884-1			
Clause	Requirement + Test	Result - Remark	Verdict

12.2.5	TABLE: test with apparatus shown in figure 11 (screw-type terminals)			
	rated current (A)	16 A		—
	type of conductors	rigid solid / rigid stranded / flexible		—
	smallest/largest cross-sectional area per table 3 (mm ²)	1,5 mm ² / 2,5 mm ²		—
	number of conductors.....	1		—
	nominal diameter of thread (mm); torque per table 6 (Nm)	Ø 3,4 mm ; 0,8 Nm		—
Cross-sectional area (mm ²)	Diameter of bushing hole per table 9 (mm)	Height H per table 9 (mm)	Mass (kg)	Remarks
1,5	6,5	260	0,4	P
2,5	9,5	280	0,7	P
supplementary information:				

12.2.6	TABLE: pull test (screw-type terminals)			
	rated current (A)	16 A		—
	smallest/largest cross-sectional area per table 3 (mm ²)	1,5 mm ² / 2,5 mm ²		—
	nominal diameter of thread (mm); torque 2/3 per table 6 (Nm)	Ø 3,4 mm ; 0,53 Nm		—
Cross-sectional area (mm ²)	Number of conductors	Type of conductors (rigid solid / rigid stranded / flexible)	Pull per table 4 applied for 1 min (N)	Remarks
1,5	1	rigid solid	50	P
2,5	1	rigid solid	50	P
supplementary information:				

IEC 60884-1			
Clause	Requirement + Test	Result - Remark	Verdict

12.2.7 TABLE: tightening test (screw-type terminals)				
	rated current (A)	16A		—
	nominal diameter of thread (mm); torque 2/3 per table 6 (Nm)	Ø 3,4 mm ; 0,53 Nm		—
Largest cross-sectional area per table 3 (mm ²)	Permissible number of conductors ⁽¹⁾	Type of conductors (rigid solid / rigid stranded / flexible)	Number of wires and nominal diameter of wires per table 5	Remarks
2,5	2	rigid solid	1x1,78	P
2,5	2	rigid stranded	7x0,67	P
supplementary information: ⁽¹⁾ terminals intended for looping-in 2 or 3 conductors				

17.1 TABLE: insulation resistance			
Item per 17.1	test voltage applied between:	measured (MΩ)	required (MΩ)
a)	between all poles connected together and the body, the measurement being made with a plug in engagement	> 5 MΩ	5 MΩ
b)	between each pole in turn and all others, these beings connected to the body with a a plug in engagement	> 5 MΩ	5 MΩ
supplementary information:			

17.2 TABLE: electric strength			
	rated voltage (V)	250 V	—
item per 17.1	test voltage applied between:	test voltage (V)	flashover / breakdown (Yes/No)
a)	Between all poles connected together and the body, with a plug in engagement	2000	P
b)	Between each pole in turn and all others connected to the body, with a plug in engagement	2000	P
supplementary information:			

19.1	TABLE: temperature rise test for socket-outlets and plugs	*See Attachment
------	---	-----------------

20	TABLE: breaking capacity	* See Attachment
----	--------------------------	------------------

21	TABLE: normal operation	* See Attachment
----	-------------------------	------------------

22	TABLE: force necessary to withdraw the plug	* See Attachment
----	---	------------------

IEC 60884-1			
Clause	Requirement + Test	Result - Remark	Verdict

24.1	TABLE: impact test			
part of enclosure tested per table 21 (A, B, C, D)	blows per part	height of fall (mm)	comments	
A	5	100	P	
B	4	100	P	
supplementary information:				

25.2	TABLE: ball pressure test of insulating materials			
	allowed impression diameter (mm)	≤ 2 mm		—
part under test	test temperature (°C)	impression diameter (mm)		
Base	125	<2		
support shutter	125	<2		
Frontal surface	125	<2		
supplementary information: (test carried out on all samples quoted on “general product information”)				

26.1	TABLE: threaded part torque test					
threaded part identification	diameter of thread (mm)	column number (1, 2 or 3)	applied torque (Nm)	times (5/10)	no damage	
screw-type terminals	3,4	2	0,8	5	P	
supplementary information:						

27.1	TABLE: creepage distances, clearances and distances through sealing compound							
	rated voltage (V)	250 V					—	
item per table 23	creepage distance dcr, clearance cl and distance through sealing compound dtsc at/of:	required cl (mm)	cl (mm)	required dcr (mm)	dcr (mm)	required dtsc (mm)	dtsc (mm)	
1/6	Between live parts of different polarity	≥ 3	>4	≥ 3	>4	≥	-	
2/7	Between live parts and parts of earthing circuit	≥ 3	>4	≥ 3	>4	≥	-	
supplementary information:								

28.1.1	TABLE: glow-wire test		
--------	-----------------------	--	--

IEC 60884-1			
Clause	Requirement + Test	Result - Remark	Verdict

part under test	material designation	test temperature (°C)	visible flame and sustained glowing (Y/N)	flame and glowing extinction time	ignition of the tissue paper (Y/N)
Base	PC	850	Y	N	N
support shutter	PC	850	Y	N	N
Frontal surface	PC	650	N	N	N
supplementary information: (test carried out on all samples quoted on “general product information”)					

List of test equipment used:

Measurement/Testing	Testing /measuring equipment/ material used, (Equipment ID)	Last calibration date	Calibration due date
Mechanical strength	torque screwdriver S-5568	15/11/17	31/11/18
Insulation resistance	Insulation resistance meter S-00390	26/03/18	31/03/19
Temperature rise	Amperometric clamp S-04697	06/04/18	30/04/19
	Multimeter S-03424	12/01/18	31/01/19
	Thermometer S-4652	15/05/18	31/05/19
Dimension	Caliper S-04319	24/10/17	31/11/18
Resistance of insulating material to abnormal heat, to fire and to tracking	digital stopwatch S-03031	31/03/18	31/03/19
	Thermocouple Type K S-07554	21/04/18	30/04/19

IEC 60884-1 ATTACHMENT			
Clause	Requirement + Test	Result - Remark	Verdict
ATTACHMENT TO TEST REPORT IEC 60884-1 ITALIAN NATIONAL DIFFERENCES Plugs and socket-outlets for household and similar purposes Part 1: General requirements			
Differences according to.....: CEI 23-50:2007 + V1:2008 + V2:2011 + V3:2015			
Attachment Form No.....: IT_ND_IEC60884_1D			
Attachment Originator: IMQ			
Master Attachment.....: Date 2015-09			
Copyright © 2015 IEC System of Conformity Assessment Schemes for Electrotechnical Equipment and Components (IECEE System). All rights reserved.			

	NATIONAL DIFFERENCES	
--	----------------------	--

7	CLASSIFICATION		
7.1.5	Add:		
	Accessories with screwless terminals for rigid conductors only are not allowed		N/A
7.2.1	Replace:		
	Socket-outlets: have increased protection		P
7.2.2	Replace:		
	Socket-outlets: provided with shutters		P
7.2.101	Add:		
	Type of possible receptivity	single / multiple	P
7.3	Add:		
	Class of appliance (class 0 not admitted)	I / II	P

8	MARKING		
8.3	Replace:		
	Cover plates necessary for safety purposes and intended to be sold separately: marked with the manufacturer's or responsible vendor's name; the type reference may be put on the smallest package unit		N/A

9	CHECKING OF DIMENSIONS		
9.1	Replace the first paragraph:		
	Accessories comply with the appropriate Italian standard sheets	See annex 1	P
	Add after the fourth paragraph:		

IEC 60884-1 ATTACHMENT			
Clause	Requirement + Test	Result - Remark	Verdict
	Plugs according to standard sheets S30, S31, S32: coupling with socket-outlet P30 checked by:		
	- gauge C7 (ex CEI UNEL 09321-64 B)		N/A
	- gauge C8 (ex CEI UNEL 09323-64 B)		N/A
	- gauge C10 (ex CEI UNEL 09336-64)		N/A
	Add after the last paragraph:		N/A
	Socket-outlets according to standard sheets P10, P11, P17/11, P30: easy insertion and withdrawal of plugs complying with Standard CEI EN 50075		P
	Socket-outlets according to standard sheets P11, P17, P17/11 with rim or recess and socket-outlets according to standard sheet P30: simultaneous contact on live socket-contact by plug complying with standard sheet SPA11, SPB11, SPA17, SPB17 not possible; checked by:		
	- gauge A (standard sheet C2)		N/A
	- gauge B (standard sheet C2)		N/A
	Add:		
9.2.101	Multiple receptivity socket-outlets according to standard sheets P17/11: plugs complying to standard sheets S30, S31 and S32 do not make contact with live socket-contact; checked by:		
	Gauge according to standard sheets C12 applied to the pins entry holes with force of 150 N for 1 min; depth not greater than 3 mm (mm): Max 0,5 mm		P
9.3	Add:		
	Accessories with variable configuration of part relevant to connection (for example distance and diameter of pins): not admitted		N/A

10	PROTECTION AGAINST ELECTRIC SHOCK		
10.3	Replace:		
	Contact between a pin of a plug and a live socket-contact of a socket-outlet while any other pin is accessible: not possible		P
	A gauge having the dimensions given in subclause 22.1, is applied with a force of 75 N for 1 min, maintaining it perpendicular to the front surface of the socket-outlet:		
	- one live pins of the gauge is positioned against one entry hole of live socket-contacts of socket-outlet under test: it is not possible to make an electrical contact between the live socket-contacts of the socket-outlet and the pins of the gauge		P
	- one live pins and the earthing pin of the gauge is positioned against two entry holes of socket-contacts such as the live pin is positioned on the hole of earthing socket-contact and the earthing pin is positioned on the hole of live socket-contact: it is not possible to make an electrical contact between the live socket-contacts of the socket-		P

IEC 60884-1 ATTACHMENT			
Clause	Requirement + Test	Result - Remark	Verdict
	outlet and the pins of the gauge		
10.101	Add:		
	Plugs: live parts not accessible		N/A
	Test wire of 1 mm diameter (figure 10) applied with a force of 1 N on all accessible surfaces of plugs inserted in the relevant socket-outlets does not touch live parts		N/A
	Accessories with electromeric or thermoplastic material: test carried out at $(35 \pm 2) ^\circ\text{C}$		N/A

12	TERMINALS AND TERMINATIONS		
12.1.1	Add:		
	Note: socket-outlets for appliances may be provided with male tabs of flat-quick connect terminations (tests under consideration)		N/A
12.1.2	Replace the last sentence of the first paragraph:		
	Screw-type terminals, screwless terminals, flat-quick connect terminations, insulation-piercing clamping units or similar connections: not admitted in non-rewirable accessories		N/A
12.2	Looping-in of three conductors of 2.5 mm^2 or two conductors of 4 mm^2 is not required for 16 A, 2P and 2P+E fixed socket-outlets (Table 3)		P
12.3	Add:		
	Screwless terminals: used in fixed socket-outlets only		N/A

16	RESISTANCE TO AGEING, PROTECTION PROVIDED BY ENCLOSURES, AND RESISTANCE TO HUMIDITY		
	Add after the fifth paragraph		
16.1	Portable socket-outlets:		
	- test plug complying to this Standard sheet (found on the market) inserted into the socket-outlets	S11 for P11 S17 for P17/11 and P17 S30 for P30	N/A
	Portable socket-outlet provided with cover: the cover is closed during the test		N/A
	After the test:		
	Verification of the minimum withdrawal force (single-pin gauge)		
	- Minimum withdrawal force (N)		—
	The plug not fall from each individual contact-assembly within 30 s		N/A

IEC 60884-1 ATTACHMENT			
Clause	Requirement + Test	Result - Remark	Verdict
17	INSULATION RESISTANCE AND ELECTRIC STRENGTH		
	Add new sentences after the first paragraph:		
	One pole of all pilot lights is disconnected for these tests		N/A
	All other components connected between live poles are disconnected		N/A

18	OPERATION OF EARTHING CONTACTS		
	Add (type P30 socket-outlets):		
	Checked by measuring the force exerted by the side earthing contacts by means of the device shown in Figure 101:		
	The average value of the forces necessary to move each contact to the indicated position is ≥ 5 N (N)		N/A

19	TEMPERATURE RISE		
	Amendment (plug):		
	Plugs tested with clamping units having dimensions specified in Figure 44 (modified) fitted on each live pin and earthing pin, if any		N/A
	Add (multiple receptivity socket-outlets):		
	<i>Set of three samples (MNO) without shutters, submitted to the test expected for 10 A socket-outlets</i>		
	Test current as specified in table 20 passed for 1 h (A)	16A	—
	Temperature rise of terminals not exceed 45 K	max -29,1 K	P
	Separate tests made passing the current through:		
	- the neutral contact, if any, and the adjacent phase contact (K)	max - K	N/A
	- the earthing contact, if any, and the nearest phase contact (K)	max – 28,6 K	P
	Temperature rise of external parts of insulating material not necessary to retain current-carrying parts and parts of the earthing circuit in position (K)	max – 8,3 K	P
	<i>Set of three samples (PQR) without shutters, submitted to the test expected for 16 A socket-outlets</i>		
	Test current as specified in table 20 passed for 1 h (A)	22A	—
	Temperature rise of terminals not exceed 45 K	max – 33,6 K	P
	Separate tests made passing the current through:		

IEC 60884-1 ATTACHMENT			
Clause	Requirement + Test	Result - Remark	Verdict
	- the neutral contact, if any, and the adjacent phase contact (K)	max - K	N/A
	- the earthing contact, if any, and the nearest phase contact (K)	max – 33,7 K	P
	Temperature rise of external parts of insulating material not necessary to retain current-carrying parts and parts of the earthing circuit in position (K)	max – 9,0 K	P
19.3	Add in the first and the third dash:		
	Incorporated components are short circuited when connected in series, while are disconnected when connected between live poles		N/A
	Add in the second and fourth dash:		
	When the incorporated components require power supply for their correct operation, the test is carried out at the rated voltage		N/A

20	BREAKING CAPACITY		
	Add (multiple receptivity socket-outlets):		
	<i>Set of three samples (MNO) without shutters, submitted to the test expected for 10 A socket-outlets</i>		
	100 strokes; 30 strokes per minute; 275 V; 12,5 A; cos φ 0,6		P
	<i>Set of three samples (PQR) without shutters, submitted to the test expected for 16 A socket-outlets</i>		
	100 strokes; 30 strokes per minute; 275 V; 20 A; cos φ 0,6		P
	<i>Set of three samples (STU) without shutters, submitted to the test expected for 10 and 16 A socket-outlets</i>		
	50 strokes; 30 strokes per minute; 275 V; 12,5 A; cos φ 0,6		P
	50 strokes; 30 strokes per minute; 275 V; 20 A; cos φ 0,6		P
	During the test: no sustained arcing occur		P
	After the test:		
	- specimens show no damage impairing their further use;		P
	- entry holes for the pins not show any damage which may impair the safety		P

21	NORMAL OPERATION		
	Add (multiple receptivity socket-outlets):		

IEC 60884-1 ATTACHMENT			
Clause	Requirement + Test	Result - Remark	Verdict
	<i>Set of three samples (ABC) with shutters, submitted to the test expected for 10 A socket-outlets</i>		
	10000 strokes without current carried out with 10 A test plug		P
	After the test the following gauges applied to the entry holes corresponding to live contacts do not touch live parts when they remain under the relevant forces:		
	- Gauge of figure 9, applied with a force of 20 N, for approximately 5 s, successively in three directions		P
	- Steel gauge of figure 10, applied with a force of 1 N for approximately 5 s, in three directions		P
	<i>Set of three samples (JKL) with shutters, submitted to the test expected for 16 A socket-outlets</i>		
	10000 strokes without current carried out with 16 A test plug		P
	After the test the following gauges applied to the entry holes corresponding to live contacts do not touch live parts when they remain under the relevant forces:		
	- Gauge of figure 9, applied with a force of 20 N, for approximately 5 s, successively in three directions		P
	- Steel gauge of figure 10, applied with a force of 1 N for approximately 5 s, in three directions		P
	<i>Set of three samples (MNO) without shutters, submitted to the test expected for 10 A socket-outlets</i>		
	10000 strokes; 30 strokes per minute; 250 V; 10 A; $\cos \varphi$ 0,8		P
	During the test: no sustained arcing occur		P
	After the tests: no damage		P
	Temperature-rise test (requirements of clause 19, test current: 10 A):		
	Temperature rise of terminals not exceed 45 K :	max – 14,8K	P
	Separate tests made passing the current through:		
	the neutral contact, if any, and the adjacent phase contact (K)	max - K	N/A
	the earthing contact, if any, and the nearest phase contact (K)	max – 13,6 K	P
	Electric strength (sub-clause 17.2), test voltage (a.c., for 1 min):		
	a) test voltage (V)	1000 V / 1500 V	P
	b) test voltage (V)	1000 V / 1500 V	P
	c) test voltage (V)	1000 V / 1500 V	N/A
	d) test voltage (V)	1000 V / 1500 V	N/A

IEC 60884-1 ATTACHMENT			
Clause	Requirement + Test	Result - Remark	Verdict
	e) test voltage (V)	1000 V / 1500 V	N/A
	During the test: no flashover or breakdown		
	<i>Set of three samples (PQR) without shutters, submitted to the test expected for 16 A socket-outlets</i>		
	10000 strokes; 30 strokes per minute; 250 V; 16 A; cos φ 0,8		P
	During the test: no sustained arcing occur		P
	After the tests: no damage		
	Temperature-rise test (requirements of clause 19, test current: 16 A):		
	Temperature rise of terminals not exceed 45 K	max – 24,7 K	P
	Separate tests made passing the current through:		
	the neutral contact, if any, and the adjacent phase contact (K)	max – K	N/A
	the earthing contact, if any, and the nearest phase contact (K)	max – 25,3 K	P
	Electric strength (sub-clause 17.2), test voltage (a.c., for 1 min):		
	a) test voltage (V)	1000 V / 1500 V	P
	b) test voltage (V)	1000 V / 1500 V	P
	c) test voltage (V)	1000 V / 1500 V	N/A
	d) test voltage (V)	1000 V / 1500 V	N/A
	e) test voltage (V)	1000 V / 1500 V	N/A
	During the test: no flashover or breakdown		
	<i>Set of three samples (STU) without shutters, submitted to the test expected for 10 and 16 A socket-outlets</i>		
	4000 strokes; 30 strokes per minute; 250 V; 10 A; cos φ 0,8		P
	6000 strokes; 30 stroke per minute; 250 V; 16 A; cos φ 0,8		P
	During the test: no sustained arcing occur		P
	After the tests: no damage		P
	Temperature-rise test (requirements of clause 19, test current: 10 A):		
	Temperature rise of terminals not exceed 45 K	max – 14,4 K	P
	Separate tests made passing the current through:		
	the neutral contact, if any, and the adjacent phase contact (K)	max – K	N/A
	the earthing contact, if any, and the nearest phase contact (K)	max – 14,6 K	P
	Temperature-rise test (requirements of clause 19, test current: 16 A):		

IEC 60884-1 ATTACHMENT			
Clause	Requirement + Test	Result - Remark	Verdict
	Temperature rise of terminals not exceed 45 K	max – 21,3 K	P
	Separate tests made passing the current through:		
	the neutral contact, if any, and the adjacent phase contact (K)	max – K	N/A
	the earthing contact, if any, and the nearest phase contact (K)	max – 22,8 K	P
	Electric strength (sub-clause 17.2), test voltage (a.c., for 1 min):		
	a) test voltage (V)	1000 V / 1500 V	P
	b) test voltage (V)	1000 V / 1500 V	P
	c) test voltage (V)	1000 V / 1500 V	N/A
	d) test voltage (V)	1000 V / 1500 V	N/A
	e) test voltage (V)	1000 V / 1500 V	N/A
	During the test: no flashover or breakdown		

22	FORCE NECESSARY TO WITHDRAW THE PLUG		
	Add (multiple receptivity socket-outlets):		
	<i>Set of three samples (MNO) without shutters, submitted to the test conditions expected for 10 A socket-outlets</i>		
22.1	Verification of the maximum withdrawal force (multi-pin gauge)		
	- Maximum withdrawal force (N) / pins diameter (mm)	50 N / 4,06 mm	—
	The plug not remain in the socket-outlet		P
22.2	Verification of the minimum withdrawal force (single-pin gauge)		
	- Minimum withdrawal force (N) / pin diameter (mm)	1,5 N / 3,94 mm	—
	The plug not fall from each individual contact-assembly within 30 s		P
	<i>Set of three samples (PQR) without shutters, submitted to the test conditions expected for 16 A socket-outlets</i>		
22.1	Verification of the maximum withdrawal force (multi-pin gauge)		
	- Maximum withdrawal force (N) / pins diameter (mm)	54 N / 5 mm	—
	The plug not remain in the socket-outlet		P
22.2	Verification of the minimum withdrawal force (single-pin gauge)		
	- Minimum withdrawal force (N) / pin diameter (mm)	2 N / 4,91 mm	—
	The plug not fall from each individual contact-assembly within 30 s		P

IEC 60884-1 ATTACHMENT			
Clause	Requirement + Test	Result - Remark	Verdict
	<i>Set of three samples (STU) without shutters, submitted to the test conditions expected for 10 and 16 A socket-outlets</i>		
	<i>Test conditions expected for 10 A socket-outlets</i>		
22.1	Verification of the maximum withdrawal force (multi-pin gauge)		
	- Maximum withdrawal force (N) / pins diameter (mm).....	50 N / 4,06 mm	—
	The plug not remain in the socket-outlet		P
22.2	Verification of the minimum withdrawal force (single-pin gauge)		
	- Minimum withdrawal force (N) / pin diameter (mm).....	1,5 N / 3,94 mm	—
	The plug not fall from each individual contact-assembly within 30 s		P
	<i>Test conditions expected for 16 A socket-outlets</i>		
22.1	Verification of the maximum withdrawal force (multi-pin gauge)		
	- Maximum withdrawal force (N) / pins diameter (mm).....	54 N / 5 mm	—
	The plug not remain in the socket-outlet		P
22.2	Verification of the minimum withdrawal force (single-pin gauge)		
	- Minimum withdrawal force (N) / pin diameter (mm).....	2 N / 4,91 mm	—
	The plug not fall from each individual contact-assembly within 30 s		P

24	MECHANICAL STRENGTH		
24.2	Add:		
	After the test: admitted a further tolerance of -0,2 mm on pins spacing, with exception of those corresponding to standard sheets S30, S31 and S32		N/A
	Add before the Notes from 1 to 3		
	The shutters of socket-outlets tested again according to Clause 21, from paragraph 17 up to paragraph 22 (only the tests of shutters)		N/A
24.9	Add after last paragraph		
	The shutters of socket-outlets tested again according to Clause 21, from paragraph 17 up to paragraph 22 (only the tests of shutters)		N/A

26	SCREWS, CURRENT-CARRYING PARTS AND CONNECTIONS		
26.1	Add:		

IEC 60884-1 ATTACHMENT			
Clause	Requirement + Test	Result - Remark	Verdict
	Test for screws for fixing covers or cover plates also intended for decorative purposes:		
	- 10 times for screws in engagement with a thread of insulating material and for screws of insulating material		N/A
	- 5 times for all other cases		N/A
	- screw diameter (mm); torque (Nm): - mm; - Nm		—
	During the test: no damage impairing the further use of the screwed connections		N/A

Annex 1: Dimensional checking (Standard sheet P17/11 of Standard CEI 23-50:2007+ V1:2008+ V2:2011+ V3:2015) (Italian language)

Foglio di normalizzazione P17/11

16 A 250 V ~

Presa bipolare con contatto di terra a ricettività multipla

Dimensioni in millimetri

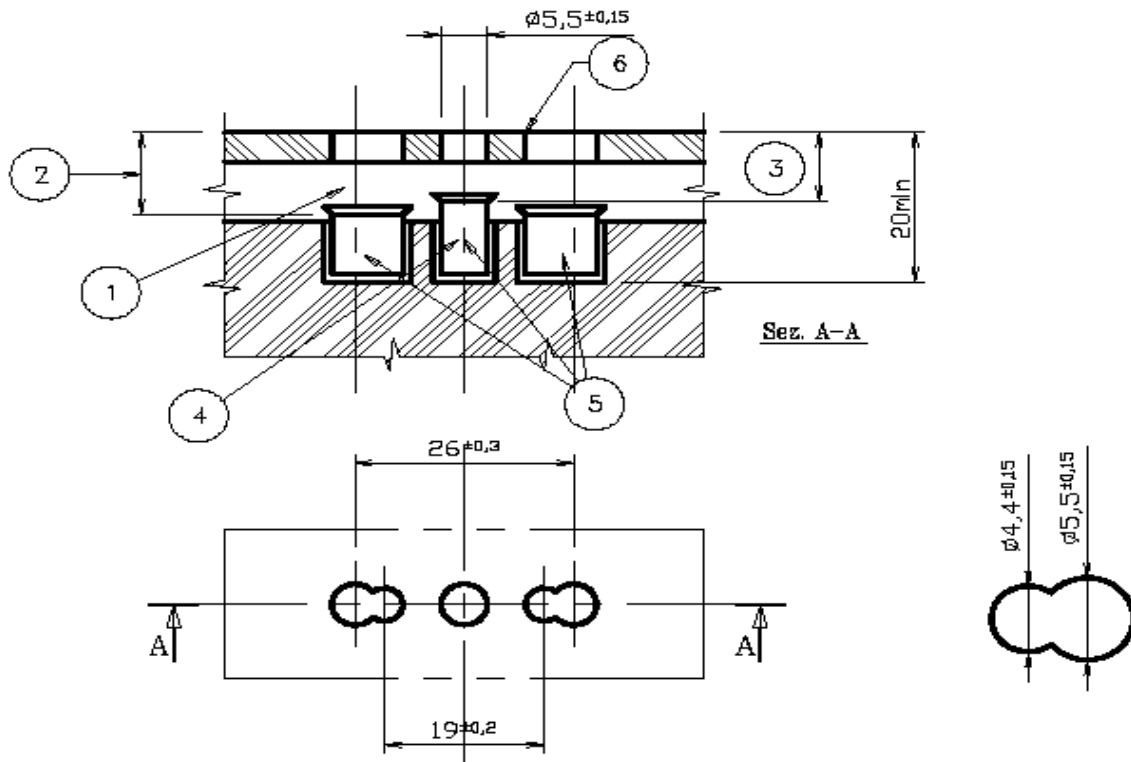

- 1) Spazio per schermi che sono obbligatori.
 - 2) Distanza tra superficie frontale della presa e punto di primo contatto degli alveoli attivi. Questa distanza deve essere compresa tra 10 mm e 13,5 mm. La verifica si effettua con calibro C1.
 - 3) Distanza tra superficie frontale della presa e punto di primo contatto dell'alveolo di terra. Questa deve essere inferiore alla distanza di cui al punto 2 e tale che:
 - quando si inserisce la spina relativa, la connessione di terra venga realizzata prima che i contatti attivi della spina vengano connessi;
 - quando si estrae la spina, i contatti attivi debbano venire separati prima dell'interruzione della connessione di terra.
 - 4) Contatto di terra.
 - 5) I contatti devono essere elastici. Essi possono avere forma diversa da quella cilindrica.
 - 6) I fori d'ingresso devono essere smussati o raggiati.
 - 7) Il foro dell'alveolo di terra deve risultare nel piano dei fori degli alveoli attivi (con tolleranza $\pm 0,15$ mm) ed in posizione centrale equidistante dai fori degli alveoli attivi (con tolleranza $\pm 0,15$ mm).
- Le parti non quotate non sono vincolate dalla presente unificazione.

Annex 1: Dimensional checking (Standard sheet P17/11 of Standard CEI 23-50:2007+ V1:2008+ V2:2011+ V3.2015) (Italian language)

Punto	Prescrizione	Risultato - Nota	Esito
1	Schermi: obbligatori		P
2	Distanza tra la superficie frontale della presa ed il punto di primo contatto degli alveoli attivi: compresa tra 10 e 13,5 mm (Verifica con il calibro C1)		P
3	Distanza tra la superficie frontale della presa ed il punto di primo contatto dell'alveolo di terra: inferiore a quella di cui al punto 2 in maniera tale che quando si inserisce la spina la connessione di terra venga realizzata prima che i contatti attivi della spina vengano connessi e che, quando si estrae la spina, i contatti attivi vengano separati prima dell'interruzione della connessione di terra.		P
4	Contatto di terra		P
5	Contatti: elastici		P
6	Fori di ingresso: smussati o raggati	<u>smussati</u> / raggati	P
7	Foro dell'alveolo di terra:		
	- nel piano dei fori degli alveoli attivi, con tolleranza $\pm 0,15$ mm	Es. 1: 0 mm Es. 2: 0 mm Es. 3: 0 mm	P
	- equidistante dai fori degli alveoli attivi con tolleranza $\pm 0,15$ mm	Es. 1: 4,6 mm Es. 2: 4,6 mm Es. 3: 4,6 mm	P

Annex 2:Photographic Documentation:

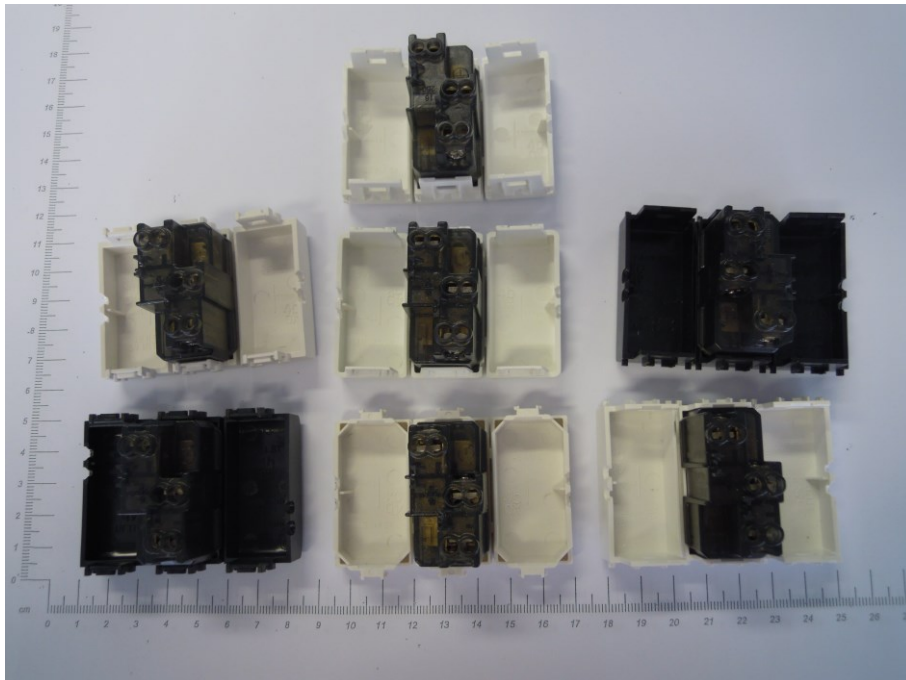
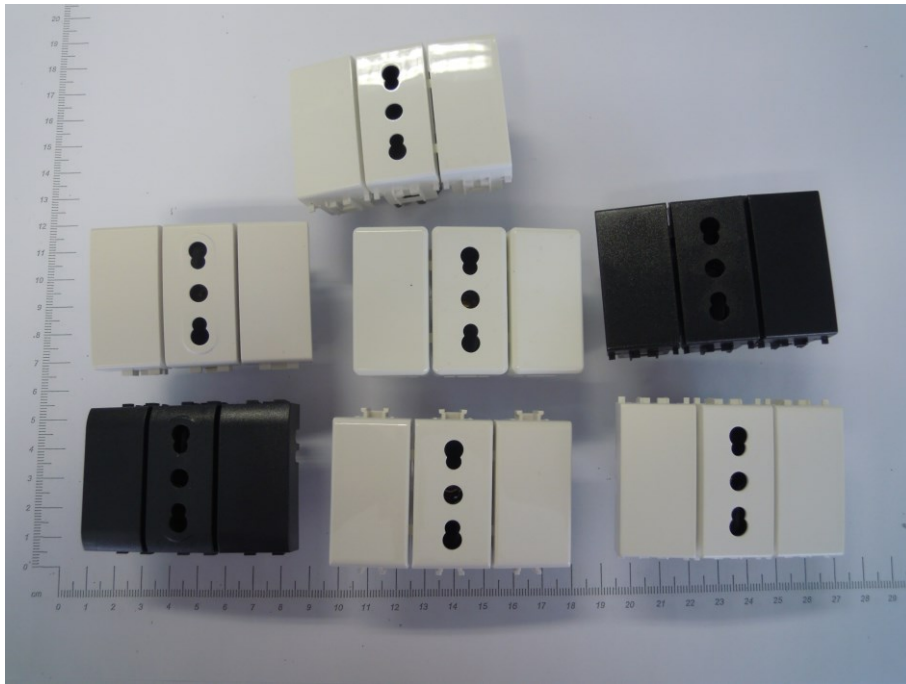

Annex 2:Photographic Documentation:

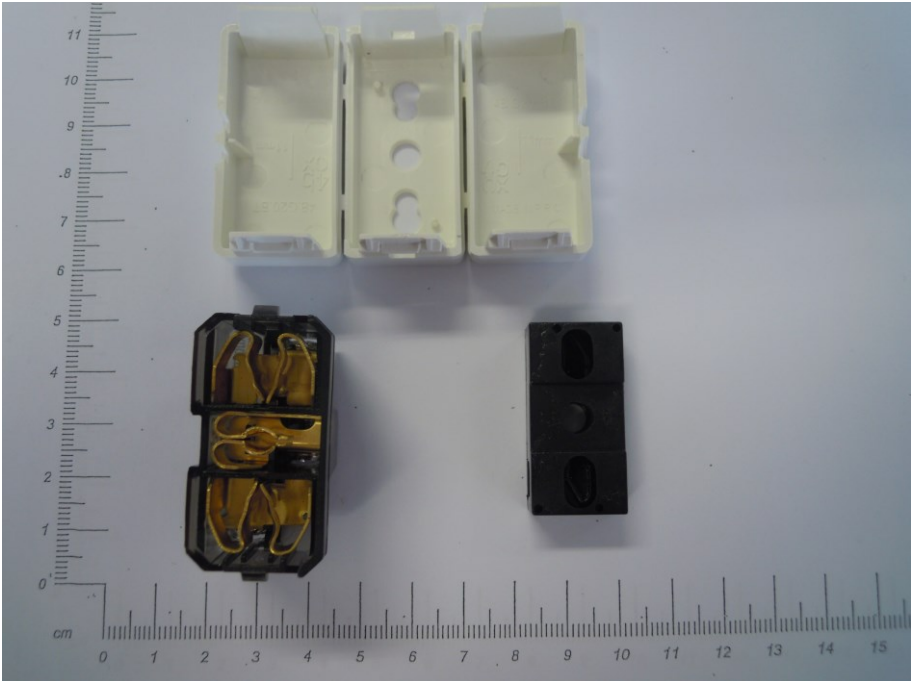
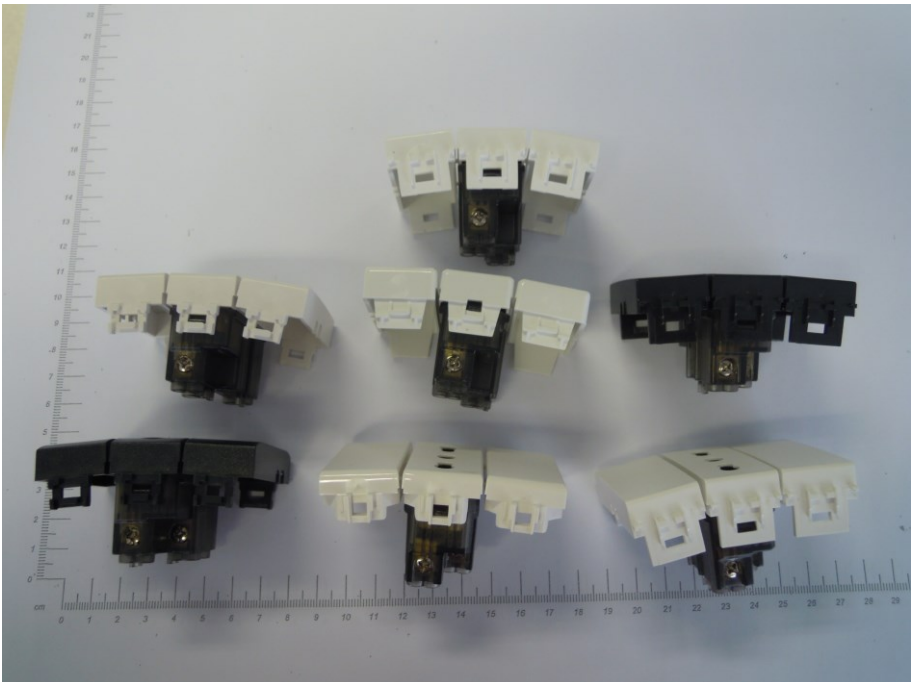

Annex 2:Photographic Documentation:

